

# Notes for Guide Bush Installation

Many of the problems in BTA drilling are caused by incorrect use of the guide bush. The shape, type and tolerance greatly affect cutting accuracy and tool life. Please note the following when using one in your application.

## 1 Resin Seal Type

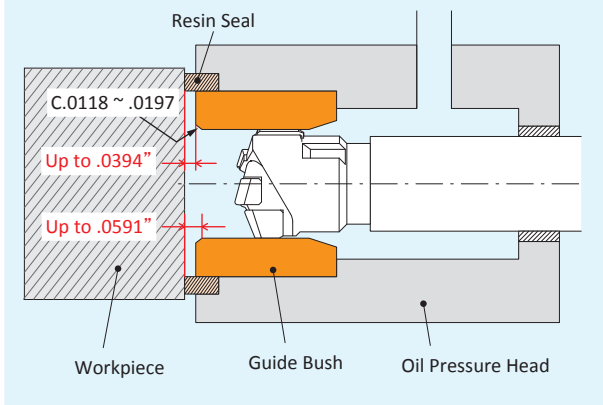

## 2 Taper Cone Type

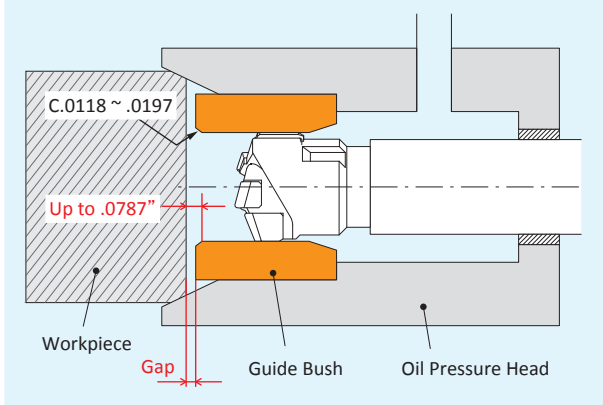

## 3 Flat-edge Type

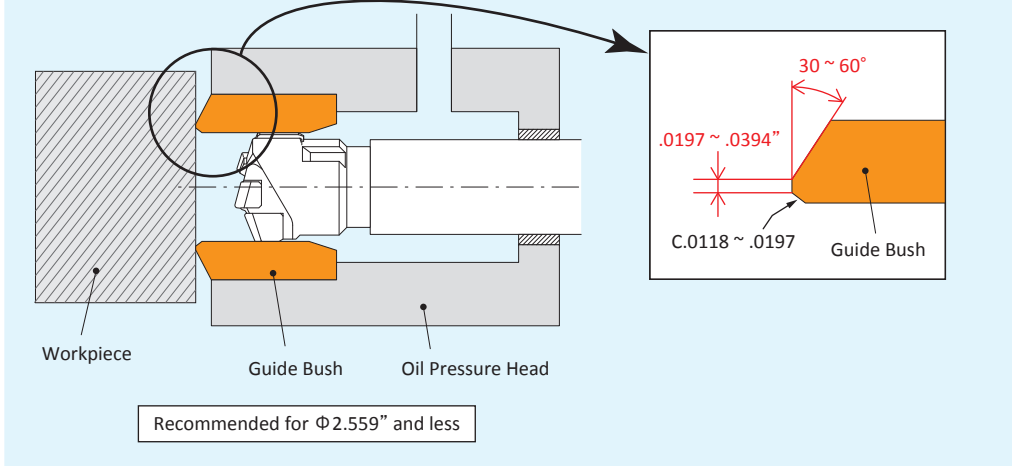

## Guide Bush Tolerance

Guide bush tolerance should be G6 in order to keep good tool life and cutting accuracy as shown below.

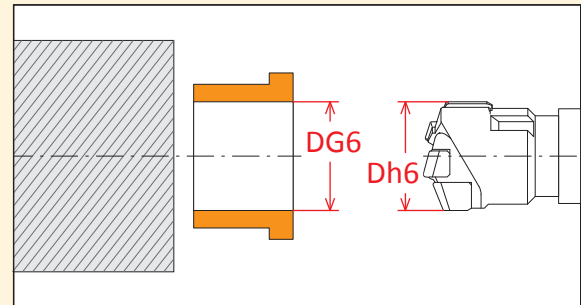

Tool Dia. D (inch)	G6 Tolerance (inch)
.315 - .393	+0.0019 ~ +0.0055
.394 - .708	+0.0023 ~ +0.0066
.709 - 1.181	+0.0027 ~ +0.0078
1.182 - 1.968	+0.0035 ~ +0.0098
1.969 - 3.150	+0.0039 ~ +0.0114
3.151 - 4.724	+0.0047 ~ +0.0133
4.725 - 7.087	+0.0055 ~ +0.0153
7.088 - 9.685	+0.0059 ~ +0.0173